

Dome 60/02

Diseño / Design:

Benedetta Tagliabue | EMBT / 2015

Tipología: Suspensión

Typology: Pendant lamp

Ambiente: Interior

Environment: Indoor

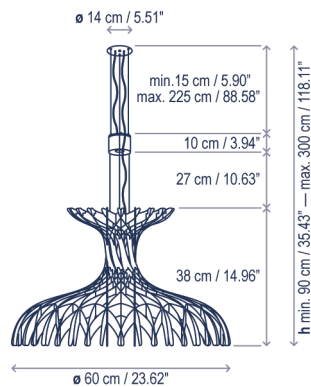

Descripción técnica / Technical description:

 **Peso Neto: 2,76 kg**
Net Weight: 2,76 kg

 **1 Caja/Box | 67 x 67 x 57 cm | 0,2559 m³**
Peso bruto / Gross Weight: 5 kg

Materiales: Hierro, Aluminio, Madera acabado haya.

Materials: Iron, Aluminum, Wood finished beech.

La fuente de luz está situada sobre la estructura, proyectando bellos mosaicos de luz en las superficies inferiores.

The light is above the structure to illuminate throughout the open and diffused portions casting beautiful shadow patterns on surfaces below.

La fuente de luz adicional de la Dome 60/02 proporciona luz directa a la superficie inferior, el LED ubicado sobre la pantalla ofrece luz de ambiente.

The additional LED source on the Dome 60/02 allows for more focused illumination on surfaces below, while the upper light provides for ambient light.

No personalizable

Not customizable

Certificaciones
Certifications



Descripción lámpara / Lamps description:

  230V 50HZ | IP-20 |   25 W LED / CRI: 90 / 2700°K
2664 lm fuente de luz / light source

Ref	Acabados / Finishing	Ean13
2580721400/P829	Regulable Triac - Blanco Mate Pantalla Madera Natural <i>Dimmable Triac - Matte White Natural Wood Shade</i>	8435493714707
2580721412/P829	Regulable Triac - Negro Mate Pantalla Madera Natural <i>Dimmable Triac - Matte Black Natural Wood Shade</i>	8435493714714

bover
barcelona lights

Avda. Catalunya 173
Polígono Ind. Sud
08440 Cardedeu
Barcelona, Spain

T. +34 938 713 152
F. +34 938 462 089
info@bover.es
www.bover.es

Familia / Family: Dome

